

hp 739A1



HEWLETT-PACKARD COMPANY / OPERATING AND SERVICE MANUAL

739AR

FREQUENCY

RESPONSE TEST SET

hp 739AR



OPERATING AND SERVICE MANUAL

MODEL 739AR

SERIALS PREFIXED: 010 -

FREQUENCY RESPONSE TEST SET

Copyright HEWLETT-PACKARD COMPANY 1959
1501 PAGE MILL ROAD, PALO ALTO, CALIFORNIA, U. S. A.



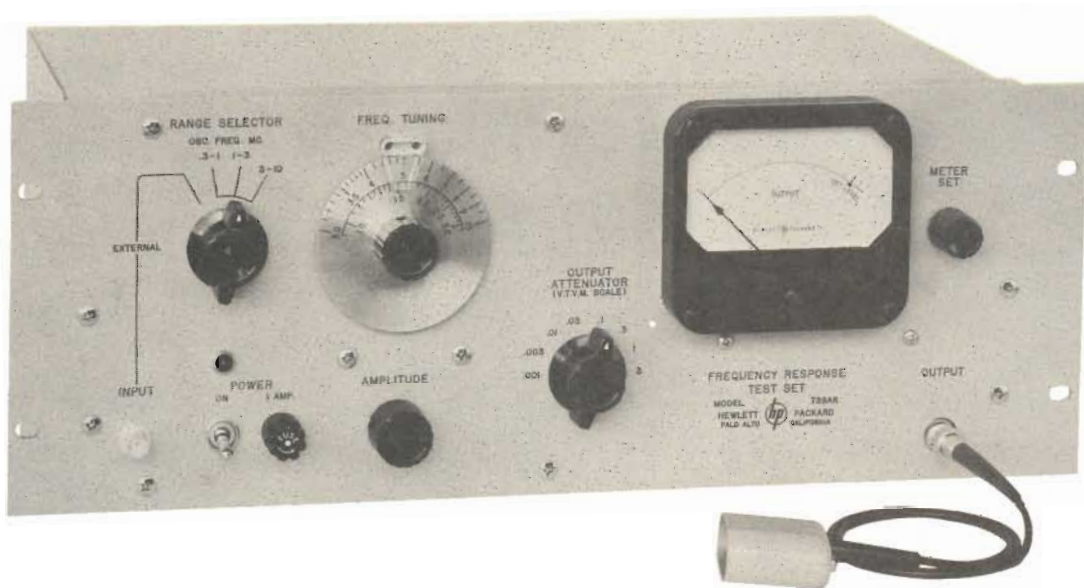

Figure 1. Model 739AR Frequency Response Test Set

SECTION I DESCRIPTION

The Φ Model 739AR Frequency Response Test Set simplifies frequency response determination by providing a convenient constant amplitude reference voltage of variable frequency. Frequency response of vacuum tube voltmeters, oscilloscopes, video amplifiers and filters from 5 cps to 10 mc (extended frequency range when used with Φ Model 200S Oscillator) can be quickly and easily checked.

The Frequency Response Test Set contains a wide range oscillator, special voltmeter, and step attenuator as shown in figure 2. The oscillator generates constant amplitude signals between 300 kc and 10 mc. The monitoring circuit is flat from 5 cps to 300 kc so that an external oscillator such as Φ Model 200S can be used to reduce the lower frequency limit to as low as 5 cps. Oscillator output is applied to the monitoring voltmeter, which samples the input to a step attenuator. An arbitrary reference level is maintained on the monitoring meter as the frequency setting is varied. The attenuator reduces the signal to an appropriate output level which appears across 50 ohms at the end of the special output cable supplied.

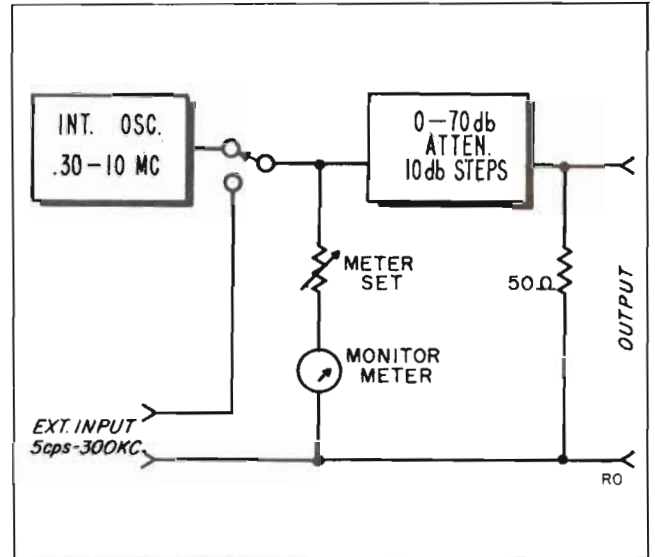

Figure 2. Model 739AR Block Diagram

Table 1. Specifications

FREQUENCY RANGE: 300 kc to 10 mc in 3 ranges.
(5 cycles to 10 mc with Model 200SR Oscillator)

REQUIREMENTS FOR EXTERNAL OSCILLATOR:
3 volts into 50 ohms, 5 cps to 300 kc, distortion less than 1%

FREQUENCY RESPONSE OF MONITORING CIRCUIT: Flat within $\pm 0.5\%$ from 10 cps to 5 mc; within $+0.5\%$, -1.5% , 5 cps to 10 mc. Monitor circuit is average reading.

OUTPUT: At least 3 volts across 50-ohm cable termination. Adjustable in 10 db steps by a 0 to 70 db attenuator. Fine adjustment provided.

POWER: 115 or 230 volts $\pm 10\%$, 50 to 1000 cps, 30 watts.

WEIGHT: Net 14 lb, shipping 28 lb

DIMENSIONS: Rack Mount

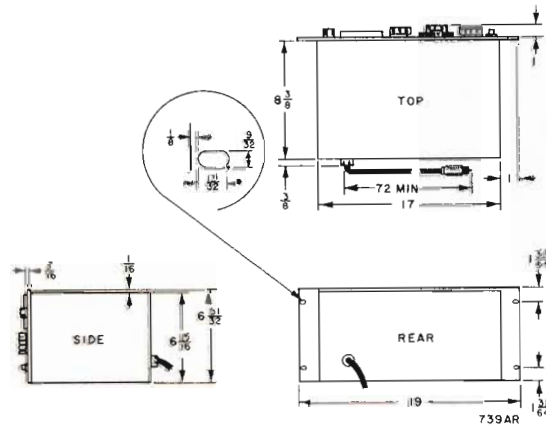

ACCESSORIES FURNISHED: 739A-16A 30 inch Output Cable, 50-ohm termination, BNC to shielded dual banana plug, (extra cables available on special order).

SECTION II OPERATION

Calibrate the device under test with an accurate voltage standard, such as the Φ Model 738A Voltmeter Calibrator. This voltage standard should have an output frequency between 100 and 1000 cps.

a. Connect the device under test to the Frequency Response Test Set OUTPUT connector, using the special terminated output cable provided.

b. Connect a suitable oscillator, such as the Φ Model 200S Oscillator, to the EXTERNAL INPUT connector on the Frequency Response Test Set.

c. Set the external oscillator to the frequency used for calibration.

d. Set the RANGE SELECTOR to EXTERNAL. Set a reference on the device under test using the external

oscillator AMPLITUDE control and the OUTPUT ATTENUATOR of the test set.

NOTE: Always use the OUTPUT ATTENUATOR range that corresponds to the desired input to the device under test. This will assure a test set meter indication near SET LEVEL.

e. Set the meter in the test set to SET LEVEL with the METER SET control.

f. Shift to any other frequency within the range of the test set or external oscillator. Return the meter to SET LEVEL using the oscillator AMPLITUDE control. Note any deviation from the reference set in step d on the device under test.

g. Repeat steps c through f if you change the range switch on the device under test. Repeat step f for all frequencies you desire to check.

SECTION III MAINTENANCE

The internal oscillator is a single pentode (V2) located inside the shield on top of the chassis. The oscillator plate and screen voltages are controlled by a series regulator triode (V1). This series regulator is controlled by a two stage differential amplifier (V3 and V4) that senses the amplitude of the voltage applied to the OUTPUT ATTENUATOR. The combined action of the series regulator, differential amplifier and output amplitude sensing circuits keeps the output constant over the range of the internal oscillator.

The power supply circuit is conventional, using glow

discharge tubes to regulate the differential amplifier voltages. Tube element voltages are not listed on the schematic diagram since they vary radically with frequency and output AMPLITUDE control setting.

The only adjustments in the oscillator circuit are for initial dial calibration and should not need further attention. Another adjustment (C16) is provided in the meter circuit. This meter frequency response adjustment should not be touched unless you have accurate means of checking the accuracy of the reference meter between 7 and 10 mc.

COPYRIGHT 1959 BY HEWLETT-PACKARD COMPANY

This drawing is intended for the operation and maintenance of Hewlett-Packard equipment and is not to be used otherwise or reproduced without written consent of the Hewlett-Packard Company.
739A-T-0108

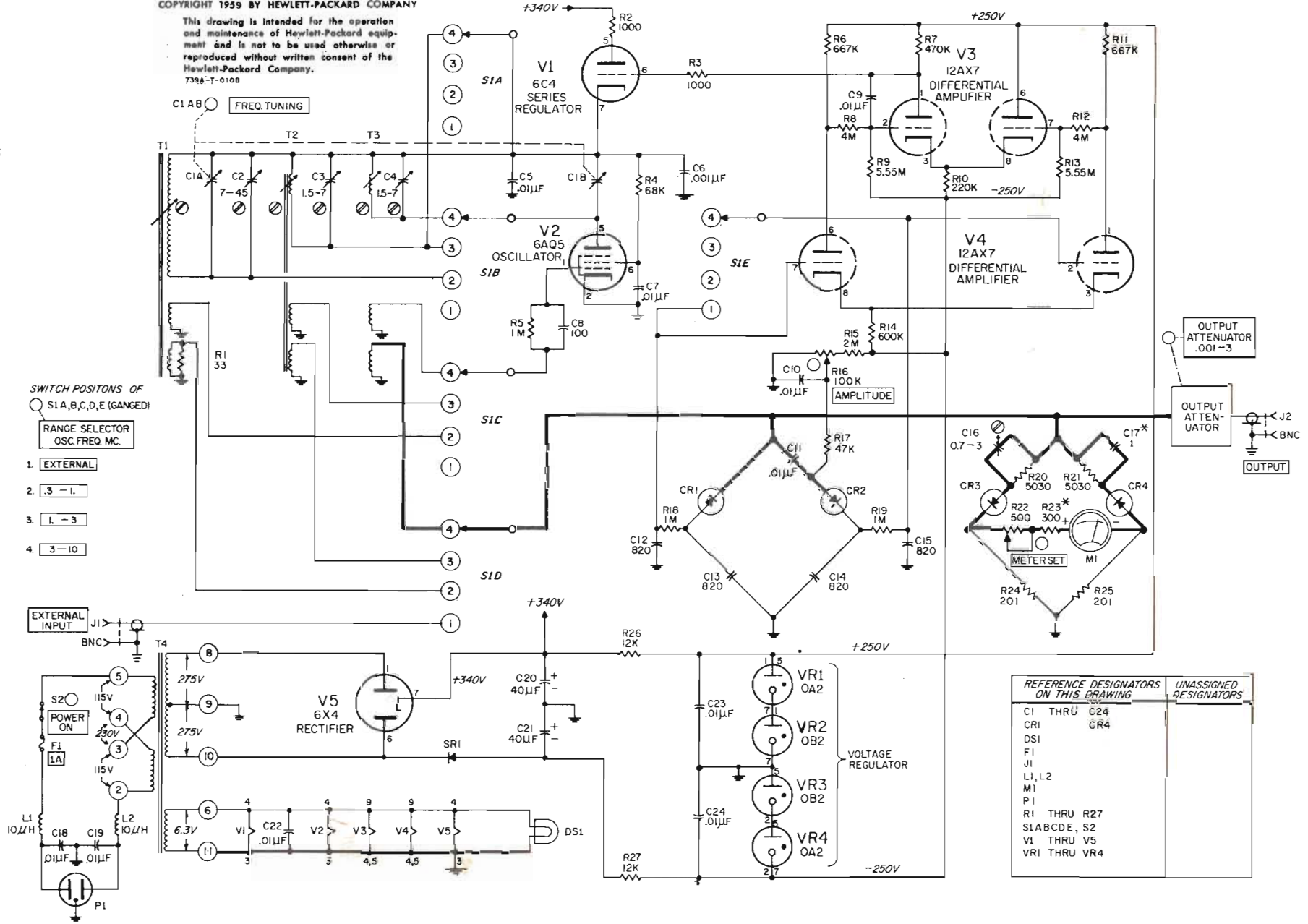

Figure 3. Model 739AR Frequency Response Test Set

SECTION IV REPLACEABLE PARTS

This section contains information for ordering replacement parts for the Model 739AR Frequency Response Test Set.

Table 2 lists replaceable parts in alpha-numerical order of their reference designators. Detailed information on a part used more than once in the instrument is listed opposite the first reference designator applying to the part. Other reference designators applying to the same part refer to the initial designator. Miscellaneous parts are included at the end of the list. Detailed information includes the following:

- a. Reference designator.
- b. Full description of the part.
- c. Manufacturer of the part in a five-digit code; see list of manufacturers in appendix.
- d. Hewlett-Packard stock number.
- e. Total quantity used in the instrument (TQ col).
- f. Recommended spare quantity for complete maintenance during one year of isolated service (RS col).

To order a replacement part, address order or inquiry either to your authorized Hewlett-Packard sales representative or to

CUSTOMER SERVICE
Hewlett-Packard Company
395 Page Mill Road
Palo Alto, California

or, in Western Europe, to
Hewlett-Packard S.A.
Rue du Vieux Billard No. 1
Geneva, Switzerland

Specify the following information for each part:

- a. Model and complete serial number of instrument.
- b. Hewlett-Packard stock number.
- c. Circuit reference designator.
- d. Description.

To order a part not listed in table 2, give a complete description of the part and include its function and location.

Table 2. Replaceable Parts

Ckt Ref.	Description	Mfr	Ⓟ Stock No.	TQ	RS		
C1	Capacitor: variable, air dielectric, 2 section, 9.5-443.2 pf	76854	0121-0026	1	1		
C2	Capacitor: variable, ceramic, 7-45 pf, 500 vdcw	72982	0130-0001	1	1		
C3, 4	Capacitor: variable, ceramic, 1 section 1.5-7 pf, 500 vdcw	72982	0130-0003	2	1		
C5	Capacitor: fixed, ceramic, .01 μ f \pm 20%, 1000 vdcw	71590	0150-0012	10	3		
C6	Capacitor: fixed, ceramic 1000 pf \pm 25%, 500 vdcw	96095	0150-0005	1	1		
C7	Same as C5						
C8	Capacitor: fixed, mica, 100 pf \pm 5%, 500 vdcw	76433	0140-0041	1	1		
C9 thru C11	Same as C5						

Table 2. Replaceable Parts (Continued)

Ckt Ref.	Description	Mfr *	Ⓢ Stock No.	TQ*	RS*		
C12, 13, 14, 15	Capacitor: fixed, mica, 820 pf $\pm 10\%$, 500 vdcw	76433	0140-0010	4	1		
C16	Capacitor: variable, polystyrene 0.7-3 pf, 350 vdcw	72982	0132-0002	1	1		
C17	Capacitor: fixed, titanium dioxide, 1 pf $\pm 10\%$, 500 vdcw Optimum value selected at factory. Average value shown.	82142	0150-0029	1	1		
C18, 19	Same as C5						
C20, 21	Capacitor: electrolytic, 2 sections, 20 μ f/sect., 450 vdcw	56289	0180-0012	2	1		
C22, 23, 24	Same as C5						
CR1, 2	Diode, germanium	73293	1910-0011	2	2		
CR3, 4	Diode, silicon	73293	1901-0027	2	2		
DS1	Lamp, miniature: 2 pin base, #12	24455	2140-0012	1	1		
F1	Fuse: 1 amp slow blow, for 115 V operation	71400	2110-0007	1	10		
	Fuse: 1/2 amp, slow blow, for 230 V operation	71400	2110-0008	1	0		
J1	Connector: part of Ext. Input Cable						
J2	Connector: part of Output Cable						
L1, 2	Inductor, RF; 10 μ h $\pm 10\%$	99848	9140-0032	2	1		
M1	Meter	65092	1120-0091	1	1		
PI	Cable, power	70903	8120-0015	1	1		
R1	Resistor: fixed, composition, 33 ohms $\pm 10\%$, 1 W	01121	0690-3301	1	1		
R2	Resistor: fixed, composition, 1000 ohms $\pm 10\%$, 1 W	01121	0690-1021	1	1		
R3	Resistor: fixed, composition, 1000 ohms $\pm 10\%$, 1/2 W	01121	0687-1021	1	1		
R4	Resistor: fixed, composition, 68,000 ohms $\pm 10\%$, 1 W	01121	0690-6831	1	1		

* See introduction to this section

Table 2. Replaceable Parts (Continued)

Ckt Ref.	Description	Mfr *	Ⓢ Stock No.	TQ*	RS*		
R5	Resistor: fixed, composition, 1 megohm $\pm 10\%$, 1/2 W	01121	0687-1051	1	1		
R6	Resistor: fixed, deposited carbon, 667,000 ohms $\pm 1\%$, 1/2 W	19701	0727-0249	2	1		
R7	Resistor: fixed, composition, 470,000 ohms $\pm 10\%$, 1/2 W	01121	0687-4741	1	1		
R8	Resistor: fixed, deposited carbon, 4 megohms $\pm 1\%$, 1/2 W	19701	0727-0298	2	1		
R9	Resistor: fixed, deposited carbon, 5.55 megohms $\pm 1\%$, 1/2 W	19701	0727-0300	2	1		
R10	Resistor: fixed, composition, 220,000 ohms $\pm 5\%$, 1/2 W	01121	0686-2245	1	1		
R11	Same as R6						
R12	Same as R8						
R13	Same as R9						
R14	Resistor: fixed, deposited carbon, 600,000 ohms $\pm 1\%$, 1/2 W	19701	0727-0246	1	1		
R15	Resistor: fixed, deposited carbon, 2 megohms $\pm 1\%$, 1/2 W	19701	0727-0287	1	1		
R16	Resistor: variable, composition, 100,000 ohms, linear taper	11237	2100-0063	1	1		
R17	Resistor: fixed, composition, 47,000 ohms $\pm 10\%$, 1/2 W	01121	0687-4731	1	1		
R18, 19	Resistor: fixed, composition, 1 megohm $\pm 10\%$, 1/2 W	01121	0687-1051	2	1		
R20, 21	Resistor: fixed, deposited carbon, 5030 ohms $\pm 1\%$, 1/2 W	19701	0727-0136	2	1		
R22	Resistor: variable, composition, linear taper, 500 ohms $\pm 10\%$	71590	2100-0019	1	1		
R23	Resistor: fixed, deposited carbon, 300 ohms $\pm 1\%$, 1/2 W Optimum value selected at factory. Average value shown.	19701	0727-0065	1	1		
R24, 25	Resistor: fixed, deposited carbon, 201 ohms $\pm 1\%$, 1/2 W	19701	0727-0055	2	1		
R26, 27	Resistor: fixed, composition, 12,000 ohms $\pm 10\%$, 2 W	01121	0693-1231	2	1		
S1	Switch, rotary: 2 sect. 4 pos	76854	3100-0085	1	1		
S2	Switch, toggle: SPST, 250 V, 3 amp	04009	3101-0001	1	1		

* See introduction to this section

Table 2. Replaceable Parts (Continued)

Ckt Ref.	Description	Mfr *	Ⓢ Stock No.	TQ*	RS*		
SR1	Rectifier, metal 162 V rms max, 20 ma dc max	77638	1883-0005	1	1		
T1	Transformer, RF	28480	739A-60A	1	1		
T2	Transformer, RF	28480	739A-60B	1	1		
T3	Transformer, RF	28480	739A-60C	1	1		
T4	Transformer, power	98734	9100-0027	1	1		
V1	Tube, electron: 6C4	86684	1921-0005	1	1		
V2	Tube, electron: 6AQ5	82219	1923-0018	1	1		
V3, 4	Tube, electron: 12AX7	00001	1932-0030	2	2		
V5	Tube, electron: 6X4	33173	1930-0016	1	1		
VR1	Tube, electron: voltage regulator, OA2	86684	1940-0004	2	2		
VR2, 3	Tube, electron: voltage regulator, OB2	86684	1940-0007	2	2		
VR4	Same as VR1						
	<u>MISCELLANEOUS</u>						
	Attenuator assembly	28480	739A-34	1	1		
	Cable assembly: Ext. Input	28480	739A-16B	1	0		
	Cable assembly: Output	28480	739A-16A	1	1		
	Fuseholder: extractor post type	75915	1400-0084	1	1		
	Knob: METER SET	28480	G-74C	2	0		
	Knob: AMPLITUDE	28480	G-74F	1	0		
	Knob: RANGE SELECTOR, OUTPUT ATTENUATOR	28480	G-74N	2	0		

* See introduction to this section

APPENDIX
CODE LIST OF MANUFACTURERS (Sheet 1 of 2)

The following code numbers are from the Federal Supply Code for Manufacturers Cataloging Handbooks H4-1 (Name to Code) and H4-2 (Code to Name) and their latest supplements. The date of revision and the date of the supplements used appear at the bottom of each page. Alphabetical codes have been arbitrarily assigned to suppliers not appearing in the H4 handbooks.

CODE NO.	MANUFACTURER	ADDRESS	CODE NO.	MANUFACTURER	ADDRESS	CODE NO.	MANUFACTURER	ADDRESS
00334	Humidial Co.	Colton, Calif.	07126	Digitran Co.	Pasadena, Calif.	48620	Precision Thermometer and Inst. Co.	Philadelphia, Pa.
00335	Westrex Corp.	New York, N.Y.	07137	Transistor Electronics Corp.	Minneapolis, Minn.	49956	Raytheon Mfg. Co.	Waltham, Mass.
00373	Garlock Packing Co., Electronic Products Div.	Camden, N.J.	07138	Westinghouse Electric Corp. Electronic Tube Div.	Elmira, N.Y.	54294	Shallcross Mfg. Co.	Selma, N.C.
00656	Aerovox Corp.	New Bedford, Mass.	07261	Avnet Corp.	Los Angeles, Calif.	55026	Simpson Electric Co.	Chicago, Ill.
00779	Amp, Inc.	Harrisburg, Pa.	07263	Fairchild Semiconductor Corp.	Mountain View, Calif.	55933	Sonotone Corp.	Elmsford, N.Y.
00781	Aircraft Radio Corp.	Boonton, N.J.	07910	Continental Device Corp.	Hawthorne, Calif.	55938	Sorenson & Co., Inc.	So. Norwalk, Conn.
00853	Sangamo Electric Co., Cap. Div.	Marion, Ill.	07933	Rheem Semiconductor Corp.	Mountain View, Calif.	56137	Spaulding Fibre Co., Inc.	Tonawanda, N.Y.
00866	Goe Engineering Co.	Los Angeles, Calif.	07980	Boonton Radio Corp.	Boonton, N.J.	56289	Sprague Electric Co.	North Adams, Mass.
00891	Carl E. Holmes Corp.	Los Angeles, Calif.	08145	U.S. Engineering Co.	Los Angeles, Calif.	59446	Telex, Inc.	St. Paul, Minn.
01121	Allen Bradley Co.	Milwaukee, Wis.	08358	Burgess Battery Co. Niagara Falls, Ontario, Canada	Niagara Falls, Ontario, Canada	61775	Union Switch and Signal, Div. of Westinghouse Air Brake Co.	Pittsburgh, Pa.
01255	Litton Industries, Inc.	Beverly Hills, Calif.	08717	Sloan Company	Burbank, Calif.	62119	Universal Electric Co.	Owosso, Mich.
01281	Pacific Semiconductors, Inc.	Culver City, Calif.	08718	Cannon Electric Co. Phoenix Div.	Phoenix, Ariz.	64959	Western Electric Co., Inc.	New York, N.Y.
01295	Texas Instruments, Inc. Semiconductor Components Div.	Dallas, Texas	08792	CBS Electronics Semiconductor Operations, Div. of C.B.S. Inc.	Lowell, Mass.	65092	Weston Inst. Div. of Daystrom, Inc.	Newark, N.J.
01349	The Alliance Mfg. Co.	Alliance, Ohio	09026	Babcock Relays, Inc.	Costa Mesa, Calif.	66346	Wollensak Optical Co.	Rochester, N.Y.
01561	Chassi-Trak Corp.	Indianapolis, Ind.	09134	Texas Capacitor Co.	Houston, Texas	70276	Allan Mfg. Co.	Hartford, Conn.
01930	Amerock Corp.	Rockford, Ill.	09250	Electro Assemblies, Inc.	Chicago, Ill.	70309	Allied Control Co., Inc.	New York, N.Y.
01961	Pulse Engineering Co.	Santa Clara, Calif.	09569	Mallory Battery Co. of Canada, Ltd.	Toronto, Ontario, Canada	70485	Atlantic India Rubber Works, Inc.	Chicago, Ill.
02114	Ferroxcube Corp. of America	Saugerties, N.Y.	10411	Ti-Tal, Inc.	Berkeley, Calif.	70563	Amperite Co., Inc.	New York, N.Y.
02286	Cole Mfg. Co.	Palo Alto, Calif.	10646	Carborundum Co.	Niagara Falls, N.Y.	70903	Belden Mfg. Co.	Chicago, Ill.
02660	Amphenol Electronics Corp.	Chicago, Ill.	11236	CTS of Berne, Inc.	Berne, Ind.	70998	Bird Electronic Corp.	Cleveland, Ohio
02735	Radio Corp. of America Semiconductor and Materials Div.	Somerville, N.J.	11237	Chicago Telephone of California, Inc.	So. Pasadena, Calif.	71002	Birnbach Radio Co.	New York, N.Y.
02771	Vocaline Co. of America, Inc.	Old Saybrook, Conn.	11312	Microwave Electronics Corp.	Palo Alto, Calif.	71218	Bud Radio Inc.	Cleveland, Ohio
02777	Hopkins Engineering Co.	San Fernando, Calif.	11870	Melabs, Inc.	Palo Alto, Calif.	71286	Camloc Fastener Corp.	Paramus, N.J.
03508	G.E. Semiconductor Products Dept.	Syracuse, N.Y.	12697	Claroat Mfg. Co.	Dover, N.H.	71313	Allen D. Cardwell Electronic Prod. Corp.	Plainville, Conn.
03705	Apex Machine & Tool Co.	Dayton, Ohio	14655	Cornell Dubilier Elec. Corp.	So. Plainfield, N.J.	71400	Busmann Fuse Div. of McGraw- Edison Co.	St. Louis, Mo.
03797	Eldama Corp.	El Monte, Calif.	15909	The Daven Co.	Livingston, N.J.	71450	CTS Corp.	Elkhart, Ind.
03877	Transitron Electronic Corp.	Wakefield, Mass.	16758	Delco Radio Div. of G. M. Corp.	Kokomo, Ind.	71468	Caumon Electric Co.	Los Angeles, Calif.
03888	Pyrofilm Resistor Co.	Morristown, N.J.	18873	E. I. DuPont and Co., Inc.	Wilmington, Del.	71471	Cinema Engineering Co.	Burbank, Calif.
03954	Air Marine Motors, Inc.	Los Angeles, Calif.	19315	Eclipse Pioneer, Div. of Bendix Aviation Corp.	Teterboro, N.J.	71482	C. P. Clare & Co.	Chicago, Ill.
04009	Arrow, Hart and Hegeman Elect. Co.	Hartford, Conn.	19500	Thomas A. Edison Industries, Div. of McGraw-Edison Co.	West Orange, N.J.	71590	Centralab Div. of Globe Union Inc.	Milwaukee, Wis.
04062	Elmenco Products Co.	New York, N.Y.	19701	Electra Manufacturing Co.	Kansas City, Mo.	71700	The Cornish Wire Co.	New York, N.Y.
04222	Hi-Q Division of Aerovox	Myrtle Beach, S.C.	20183	Electronic Tube Corp.	Philadelphia, Pa.	71744	Chicago Miniature Lamp Works	Chicago, Ill.
04298	Elgin National Watch Co., Electronics Division	Burbank, Calif.	21520	Fansteel Metallurgical Corp.	No. Chicago, Ill.	71753	A. O. Smith Corp., Crowley Div.	West Orange, N.J.
04404	Dymec Division of Hewlett-Packard Co.	Palo Alto, Calif.	21335	The Fafnir Bearing Co.	New Britain, Conn.	71785	Cinch Mfg. Corp.	Chicago, Ill.
04651	Special Tube Operations of Sylvania Electronic Systems	Mountain View, Calif.	21964	Fed. Telephone and Radio Corp.	Glifton, N.J.	71984	Dow Corning Corp.	Midland, Mich.
04713	Motorola, Inc., Semiconductor Prod. Div.	Phoenix, Arizona	24446	General Electric Co.	Schenectady, N.Y.	72136	Electro Motive Mfg. Co., Inc.	Willimantic, Conn.
04732	Filtron Co., Inc. Western Division	Culver City, Calif.	24455	G. E., Lamp Division	Nela Park, Cleveland, Ohio	72354	John E. Fast & Co.	Chicago, Ill.
04773	Automatic Electric Co.	Northlake, Ill.	24655	General Radio Co.	West Concord, Mass.	72619	Dialight Corp.	Brooklyn, N.Y.
05006	Twentieth Century Plastics, Inc.	Los Angeles, Calif.	26462	Grobef File Co. of America, Inc.	Carlstadt, N.J.	72656	General Ceramics Corp.	Keasbey, N.J.
05277	Westinghouse Electric Corp., Semi-Conductor Dept.	Youngwood, Pa.	26992	Hamilton Watch Co.	Lancaster, Pa.	72758	Girard-Hopkins	Oakland, Calif.
05593	Illumitronic Engineering Co.	Sunnyvale, Calif.	28480	Hewlett-Packard Co.	Palo Alto, Calif.	72765	Drake Mfg. Co.	Chicago, Ill.
05624	Barber Colman Co.	Rockford, Ill.	33173	G. E. Receiving Tube Dept.	Owensboro, Ky.	72825	Hugh H. Eby Inc.	Philadelphia, Pa.
05729	Metropolitan Telecommunications Corp., Metro Cap. Div.	Brooklyn, N.Y.	35434	Lectrohm Inc.	Chicago, Ill.	72928	Gudeman Co.	Chicago, Ill.
05783	Stewart Engineering Co.	Soquel, Calif.	37942	P. R. Mallory & Co., Inc.	Indianapolis, Ind.	72982	Erie Resistor Corp.	Erie, Pa.
06004	The Bassick Co.	Bridgeport, Conn.	39543	Mechanical Industries Prod. Co.	Akron, Ohio	73061	Hansen Mfg. Co., Inc.	Princeton, Ind.
06555	Beede Electrical Instrument Co., Inc.	Penacook, N.H.	40920	Miniature Precision Bearings, Inc.	Keene, N.H.	73138	Helipot Div. of Beckman Instruments, Inc.	Fullerton, Calif.
06812	Torrington Mfg. Co., West. Div.	Van Nuys, Calif.	42190	Muter Co.	Chicago, Ill.	73293	Hughes Products Div. of Hughes Aircraft Co.	Newport Beach, Calif.
07115	Corning Glass Works Electronic Components Dept.	Bradford, Pa.	43990	C. A. Norgren Co.	Englewood, Colo.	73445	Amperex Electronic Co., Div. of North American Phillips Co., Inc.	Hicksville, N.Y.
			44655	Ohmite Mfg. Co.	Skokie, Ill.	73506	Bradley Semiconductor Corp.	New Haven, Conn.
			47904	Polaroid Corp.	Cambridge, Mass.	73559	Carling Electric, Inc.	Hartford, Conn.
						73682	George K. Garrett Co., Inc.	Philadelphia, Pa.
						73743	Fischer Special Mfg. Co.	Cincinnati, Ohio
						73793	The General Industries Co.	Elyria, Ohio

00015-16
Revised: 20 September 1961

From: F.S.C. Handbook Supplements
H4-1 Dated April 1961
H4-2 Dated April 1961

APPENDIX

CODE LIST OF MANUFACTURERS (Sheet 2 of 2)

CODE NO.	MANUFACTURER	ADDRESS	CODE NO.	MANUFACTURER	ADDRESS	CODE NO.	MANUFACTURER	ADDRESS
73905	Jennings Radio Mfg. Co.	San Jose, Calif.	82389	Switchcraft, Inc.	Chicago, Ill.	95354	Methode Mfg. Co.	Chicago, Ill.
74455	J. H. Winns, and Sons	Winchester, Mass.	82647	Texas Instruments, Inc., Metals and Controls Div., Spencer Products	Attleboro, Mass.	95987	Weckesser Co.	Chicago, Ill.
74861	Industrial Condenser Corp.	Chicago, Ill.	82866	Research Products Corp.	Madison, Wis.	96067	Huggins Laboratories	Sunnyvale, Calif.
74868	Industrial Products Co.	Danbury, Conn.	82877	Rotron Manufacturing Co., Inc.	Woodstock, N.Y.	96095	Hi-Q Division of Aerovox	Olean, N.Y.
74970	E. F. Johnson Co.	Waseca, Minn.	82893	Vector Electronic Co.	Glendale, Calif.	96296	Solar Manufacturing Co.	Los Angeles, Calif.
75042	International Resistance Co.	Philadelphia, Pa.	83148	Electro Cords Co.	Los Angeles, Calif.	96330	Carlton Screw Co.	Chicago, Ill.
75173	Jones, Howard B., Division of Cinch Mfg. Corp.	Chicago, Ill.	83186	Victory Engineering Corp.	Union, N.J.	96341	Microwave Associates, Inc.	Burlington, Mass.
75378	James Knights Co.	Sandwich, Ill.	83298	Bendix Corp., Red Bank Div.	Red Bank, N.J.	96493	J. W. Miller Co.	Los Angeles, Calif.
75382	Kulka Electric Mfg. Co., Inc.	Mt. Vernon, N.Y.	83594	Burroughs Corp., Electronic Tube Div.	Plainfield, N.J.	96501	Excel Transformer Co.	Oakland, Calif.
75818	Lenz Electric Mfg. Co.	Chicago, Ill.	83777	Model Eng. and Mfg., Inc.	Huntington, Ind.	97539	Automatic and Precision Mfg. Co.	Yonkers, N.Y.
75915	Litelfuse Inc.	Des Plaines, Ill.	83821	Loyd Scruggs Co.	Festus, Mo.	97966	CBS Electronics, Div. of C.B.S., Inc.	Danvers, Mass.
76005	Lord Mfg. Co.	Erie, Pa.	84171	Arco Electronics, Inc.	New York, N.Y.	98141	Axel Brothers Inc.	Jamaica, N.Y.
76210	C. W. Marwedel	San Francisco, Calif.	84396	A. J. Giesener Co., Inc.	San Francisco, Calif.	98220	Francis L. Mosley	Pasadena, Calif.
76433	Micamold Electronic Mfg. Corp.	Brooklyn, N.Y.	84411	Good All Electric Mfg. Co.	Ogallala, Neb.	98278	Microdot, Inc.	So. Pasadena, Calif.
76487	James Millen Mfg. Co., Inc.	Malden, Mass.	84970	Sarkes Tartzian, Inc.	Bloomington, Ind.	98291	Sealectro Corp.	New Rochelle, N.Y.
76530	Monadnock Mills	San Leandro, Calif.	85454	Boonton Molding Company	Boonton, N.J.	98405	Carad Corp.	Redwood City, Calif.
76545	Mueller Electric Co.	Cleveland, Ohio	85474	R. M. Bracamonte & Co.	San Francisco, Calif.	98734	Palo Alto Engineering Co., Inc.	Palo Alto, Calif.
76854	Oak Manufacturing Co.	Chicago, Ill.	85660	Koiled Kords, Inc.	New Haven, Conn.	98925	Clevite Transistor Prod. Div. of Clevite Corp.	Waltham, Mass.
77068	Bendix Corp., Bendix Pacific Div.	No. Hollywood, Calif.	85911	Seamless Rubber Co.	Chicago, Ill.	98978	International Electronic Research Corp.	Burbank, Calif.
77221	Phaotron Instrument and Electronic Co.	South Pasadena, Calif.	86684	Radio Corp. of America, RCA Electron Tube Div.	Harrison, N.J.	99109	Columbia Technical Corp.	New York, N.Y.
77342	Potter and Brumfield, Inc.	Princeton, Ind.	87473	Western Fibrous Glass Products Co.	San Francisco, Calif.	99313	Varian Associates	Palo Alto, Calif.
77630	Radio Condenser Co.	Camden, N.J.	88140	Cutler-Hammer, Inc.	Lincoln, Ill.	99515	Marshall Industries, Electron Products Division	Pasadena, Calif.
77634	Radio Essentials Inc.	Mt. Vernon, N.Y.	89473	General Electric Distributing Corp.	Schenectady, N.Y.	99707	Control Switch Division, of America	Controls Co. El Segundo, Calif.
77638	Radio Receptor Co., Inc.	Brooklyn, N.Y.	90179	U.S. Rubber Co., Mechanical Goods Div.	Passaic, N.J.	99800	Delevan Electronics Corp.	East Aurora, N.Y.
77764	Resistance Products Co.	Harrisburg, Pa.	90970	Bearing Engineering Co.	San Francisco, Calif.	99821	North Hills Electric Co.	Great Neck, L.I., N.Y.
78283	Signal Indicator Corp.	New York, N.Y.	91418	Radio Materials Co.	Chicago, Ill.	99848	Wilco Corporation	Indianapolis, Ind.
78471	Tilley Mfg. Co.	San Francisco, Calif.	91506	Augat Brothers, Inc.	Attleboro, Mass.	99934	Renbrandt, Inc.	Boston, Mass.
78488	Stackpole Carbon Co.	Sf. Marys, Pa.	91637	Dale Products, Inc.	Columbus, Neb.	99942	Hoffman Semiconductor Div. of Hoffman Electronics, Corp.	Evanston, Ill.
78553	Tinnerman Products, Inc.	Cleveland, Ohio	91662	Elco Corp.	Philadelphia, Pa.	99957	Technology Instruments Corp. of Calif.	No. Hollywood, Calif.
78790	Transformer Engineers	Pasadena, Calif.	91737	Gremer Mfg. Co., Inc.	Wakefield, Mass.			
78947	Ucinite Co.	Newtonville, Mass.	91827	K F Development Co.	Redwood City, Calif.			
79142	Yeeder Root, Inc.	Hartford, Conn.	91929	Micro-Switch Div. of Minneapolis Honeywell Regulator Co.	Freeport, Ill.			
79251	Wenco Mfg. Co.	Chicago, Ill.	92196	Universal Metal Products, Inc.	Bassett Puente, Calif.			
79963	Zlerick Mfg. Corp.	New Rochelle, N.Y.	93332	Sylvania Electric Prod. Inc., Semiconductor Div.	Woburn, Mass.			
80031	Mapco Division of Sessions Clock Co.	Morristown, N.J.	93369	Robbins and Myers, Inc.	New York, N.Y.			
80130	Times Facsimile Corp.	New York, N.Y.	93410	Stevens Mfg. Co., Inc.	Mansfield, Ohio			
80131	Electronic Industries Association Any brand tube meeting EIA standards	Washington, D.C.	93983	Insuline-Van Norman Ind., Inc. Electronic Division	Manchester, N.H.			
80207	Unimax Switch, Div. of W. L. Maxson Corp.	Wallingford, Conn.	94144	Raytheon Mfg. Co., Receiving Tube Div.	Quincy, Mass.			
80248	Oxford Electric Corp.	Chicago, Ill.	94145	Raytheon Mfg. Co., Semi- conductor Div.	Newton, Mass.			
80411	Acro Manufacturing Co.	Columbus, Ohio	94148	Scientific Radio Products, Inc.	Loveland, Colo.			
80486	All Star Products Inc.	Defiance, Ohio	94154	Tung-Sol Electric, Inc.	Newark, N.J.			
80583	Hammerlund Co., Inc.	New York, N.Y.	94197	Curtiss-Wright Corp., Electronics Div.	Carlstadt, N.J.			
80640	Stevens, Arnold, Co., Inc.	Boston, Mass.	94310	Tru Ohm Prod. Div. of Model Engineering and Mfg. Co.	Chicago, Ill.			
81030	International Instruments, Inc.	New Haven, Conn.	94682	Worcester Pressed Aluminum Co.	Worcester, Mass.			
81415	Wilkor Products, Inc.	Cleveland, Ohio	95236	Allies Products Corp.	Miami, Fla.			
81453	Raytheon Mfg. Co., Industrial Tube Division	Quincy, Mass.	95238	Continental Connector Corp.	Woodside, N.Y.			
81483	International Rectifier Corp.	El Segundo, Calif.	95263	Lecraft Mfg. Co., Inc.	New York, N.Y.			
81860	Barry Controls, Inc.	Watertown, Mass.	95264	Lerco Electronics, Inc.	Burbank, Calif.			
82042	Carter Parts Co.	Skokie, Ill.	95265	National Coil Co.	Sheridan, Wyo.			
82142	Jeffers Electronics Division of Spear Carbon Co.	Du Bois, Pa.	95275	Vitramon, Inc.	Bridgeport, Conn.			
82170	Allen B. DuMont Labs., Inc.	Clifton, N.J.						
82209	Maguire Industries, Inc.	Greenwich, Conn.						
82219	Sylvania Electric Prod. Inc., Electronic Tube Div.	Emporium, Pa.						
82376	Astron Co.	East Newark, N.J.						

00015-16
Revised: 20 September 1961

From: F.S.C. Handbook Supplements
H4-1 Dated April 1961
H4-2 Dated April 1961

THE FOLLOWING H-P VENDORS HAVE NO NUMBER ASSIGNED IN THE LATEST SUPPLEMENT TO THE FEDERAL SUPPLY CODE FOR MANUFACTURERS HANDBOOK.

0000C	Connor Spring Mfg. Co.	San Francisco, Calif.
0000F	Malco Tool and Die	Los Angeles, Calif.
0000H	Philco Corp. (Lansdale Division)	Lansdale, Pa.
0000I	Telefunken (c/o American Elite)	New York, N.Y.
0000L	Winchester Electronics, Inc.	Santa Monica, Calif.
0000M	Western Coil Div. of Automatic Ind., Inc.	Redwood City, Calif.
0000N	Nahm-Bros. Spring Co.	San Leandro, Calif.
0000P	Ty-Car Mfg. Co., Inc.	Holliston, Mass.
0000T	Texas Instruments, Inc. Metals and Controls Div.	Versailles, Ky.
0000U	Tower Mfg. Corp.	Providence, R.I.
0000V	Imperial Electronics, Inc.	Buena Park, Calif.
0000W	Webster Electronics Co. Inc.	New York, N.Y.
0000X	Spruce Pine Mica Co.	Spruce Pine, N.C.
0000Y	Midland Mfg. Co. Inc.	Kansas City, Kans.
0000Z	Willow Leather Products Corp.	Newark, N.J.

SECTION V MAINTENANCE

5-1. INTRODUCTION.

5-2. This section contains information necessary for the proper maintenance of the -hp- Model 739AR Frequency Response Test Set. This section provides Performance Checks, Adjustment and Calibration Procedures and Troubleshooting Techniques.

5-3. TEST EQUIPMENT REQUIRED.

5-4. The test equipment required to perform the operations outlined in this section is listed in Table 5-1. This table describes the type of instrument required, the critical specifications of the instrument, the type of operation where the instrument is used and the recommended model. If the specific model recommended is not available, equipment which meets or exceeds the critical specifications listed may be substituted.

5-5. PERFORMANCE CHECKS.

5-6. The performance checks are designed to check the Model 739AR against its specifications. These checks should be made upon receipt of the instrument, following repairs and as a part of periodic maintenance. No adjustments should be made internally on the instrument during the performance checks. If the instrument fails to meet specifications, locate the section of the adjustment and calibration procedure which should correct the discrepancy. If this fails, refer to the Troubleshooting Procedures.

5-7. METER SET CONTROL AND AMPLITUDE CHECK (400 cps).

5-8. This procedure uses a 200S Oscillator, a 403B AC Voltmeter and the 739AR Frequency Response Test Set.

- a. Connect the instruments as shown in Figure 5-1 using the input cable BNC to BP and the output cable (internal 50 ohm load) 739A-16A.

- b. Set the 739AR controls as follows:

RANGE SELECTOR EXTERNAL
OUTPUT ATTENUATOR 3

- c. Set the external oscillator frequency to 400 cycles and the ac voltmeter to 3 volt range.
- d. Adjust the amplitude of the external oscillator to read 2.85 volts on the ac voltmeter.
- e. Rotate the METER SET control on the 739AR to its extremities. It should vary the meter pointer above and below SET LEVEL.

5-9. FREQUENCY RESPONSE OF THE MONITORING CIRCUIT (5 cps to 300 Kc).

5-10. Remove the ac voltmeter from the test setup in Figure 5-1 and proceed as follows:

- a. Set the External Oscillator as follows:

Frequency 400 cps
AMPLITUDE CCW

- b. Set 739AR as follows:

RANGE SELECTOR External
ATTENUATOR 3

- c. Disconnect the 739AR output cable and connect the output of the 739AR to the input of the 11049A using a short cable terminated in two BNC connectors. Connect the output of the 11049A to the input of the 419A DC Null Voltmeter (10 millivolt range).

- e. Advance the 200S AMPLITUDE control for a reading of 6.5 millivolts on the DC Null Voltmeter.

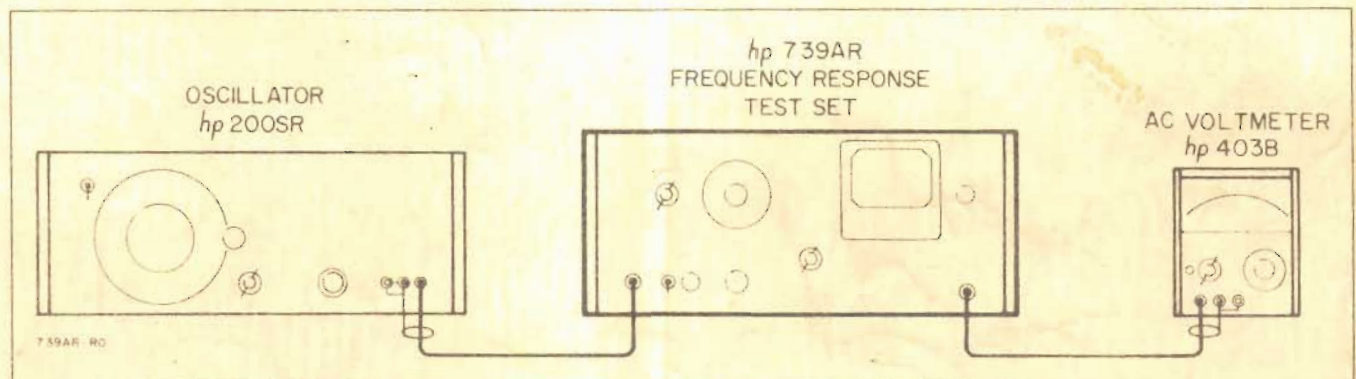

Figure 5-1. Meter Set Control and Amplitude Check Setup

CAUTION

DO NOT EXCEED 7.5 MILLIVOLT OUTPUT AS THE THERMAL CONVERTER IS EASILY DAMAGED.

- f. With the METER SET control, place the METER pointer exactly on SET LEVEL. Do not adjust the METER SET control again throughout the remaining portion of this procedure.
- g. Connect the opposing voltage supply to the 419A DC Null Voltmeter as shown in Figure 5-2. (Components are listed in Table 5-1 designated null system.)
- h. With the 739AR METER pointer on SET LEVEL, adjust the Opposing Power Supply for a null or zero reading on the 419A. Decrease the range continuing adjustment until a zero reading on the 100 microvolt range is reached.
- j. Sweep the frequency 5 cps to 300 Kc adjusting the 200S amplitude at each frequency until the 739AR METER pointer is exactly on SET LEVEL. From 5 to 10 cps, the DC Nullmeter must not vary more than +82 microvolts or -204 microvolts. From 10 cps to 300 Kc, the DC Nullmeter must not vary more than ± 82 microvolts. Sixty microvolts corresponds to 0.5% rms voltage. Considering the $\pm 0.2\%$ accuracy of the Thermal Converter, this allows a variation of the above values.

5-11. FREQUENCY RESPONSE OF THE INTERNAL OSCILLATOR MONITORING CIRCUIT (3 volts).

5-12. This is for approximately 3 volt output using the -hp- Model 11049A Thermal Converter.

NOTE

The Frequency Response of Internal Oscillator Monitoring Cir-

cuit is adjusted at the factory at the OUTPUT terminal of the 739AR. If the external output cable 739A-16A or any other long cable is used in calibrating an instrument at high frequencies, this cable should be the input to the Thermal Converter. The 50 ohm load of the cable must be removed as the Thermal Converter has a 50 ohm input. C16 on the Diode Board may be adjusted for flatness over the entire range 0.3 Mc to 10 Mc. (See Paragraph 5-29.) Replace the 50 ohm load in cable after calibration is completed.

- a. Set the 739AR controls as follows:

RANGE Selector	0.3 to 1 Mc
FREQ TUNING	3
AMPLITUDE	CCW
ATTENUATOR	3
- b. Disconnect the 739AR output cable and connect the output of the 739AR to the input of the 11049A Thermal Converter using a short cable terminated in two BNC jack connectors. Connect the output of the 11049A to the input of the -hp- Model 419A DC Null Voltmeter (10 millivolt range).
- c. Advance the 739AR AMPLITUDE control until the 419A reads 6.5 millivolts output. (Use METER SET control to set marker exactly on SET LEVEL.)

CAUTION

DO NOT EXCEED 7.5 MILLIVOLT OUTPUT AS THE THERMAL CONVERTER IS EASILY DAMAGED.

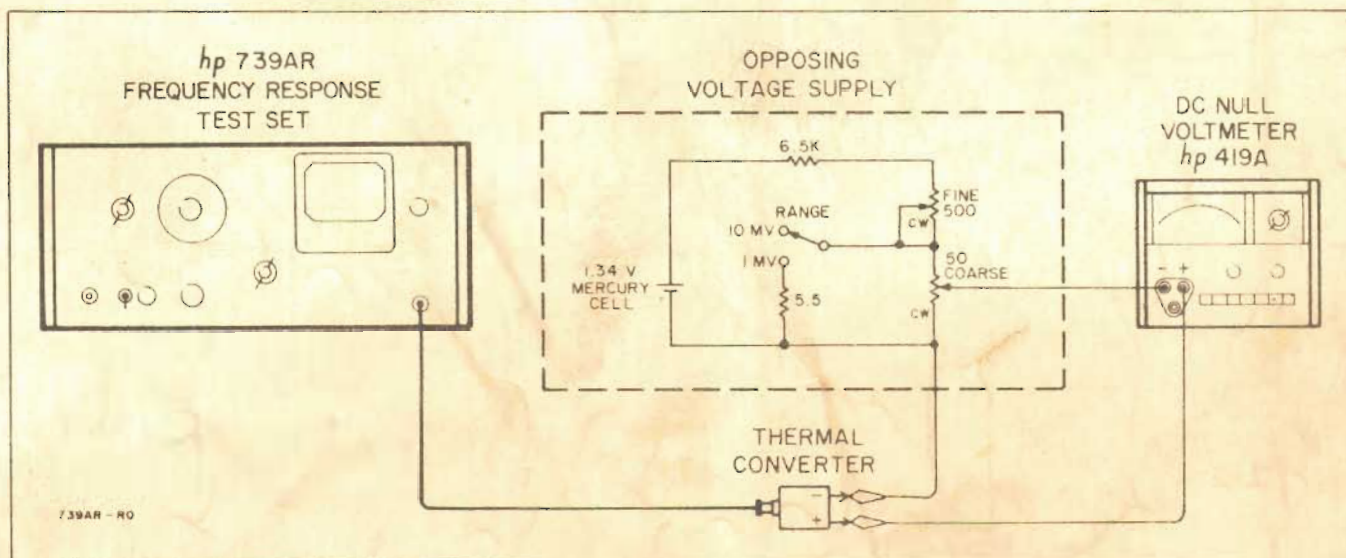

Figure 5-2. Frequency Response of the Monitoring Circuit

- e. When pointer is exactly over zero, rotate the adjustment screw a few degrees counterclockwise or enough to free the adjustment screw from the meter suspension. If the pointer moves during this step, repeat steps c through e.

5-22. For all of the following adjustments, the 739AR must be removed from its case. Remove two screws from the rear panel and two screws from each side of the front panel. Slide chassis from the case.



THE FRAME OF THE TUNING CAPACITORS NORMALLY HAS A POTENTIAL OF APPROXIMATELY +150 VOLTS.

5-23. FREQUENCY CALIBRATION PROCEDURE.

5-24. Connect the OUTPUT of the 739AR to the input of the 524D Electronic Counter using the 739A-16A Output Cable and an -hp- Model 10110A BNC to banana jack adapter.

5-25. CALIBRATION FOR THE 3 TO 10 MC RANGE.

- a. Set the 739AR controls as follows:

RANGE Selector	3 Mc to 10 Mc
FREQ TUNING Dial	3
ATTENUATOR	3
AMPLITUDE	Adjust until METER reads SET LEVEL
- b. Turn FREQ TUNING dial until the 524D reads 3 megacycles. Remove dial knob and slightly loosen screws under knob. Slip dial until 3 is directly under the marker on readout window. Tighten screws and replace knob.
- c. Turn FREQ TUNING dial to 10. Adjust C4 (designated on internal shield) until 10 Mc is read on the 524D. (Check at 5 Mc and at 8 Mc to see that they are within 6% of reading.

NOTE

The other two ranges should be calibrated whenever the 3 to 10 Mc range is calibrated.

5-26. CALIBRATION OF THE 1 MC TO 3 MC RANGE.

- a. Set 739AR RANGE SELECTOR to 1 Mc to 3 Mc range.
- b. Set FREQ TUNING dial to 1.
- c. Adjust slug in T₂ for 1 Mc output as read on the 524D Electronic Counter. (See Figure 5-3 for location.)
- d. Rotate FREQ TUNING dial to 3.
- e. Adjust C3 for 3 Mc output.

5-27. CALIBRATION OF THE 0.3 MC TO 1 MC RANGE.

- a. Set 739AR RANGE SELECTOR to 0.3 Mc to 1 Mc range. FREQ TUNING dial to 3.
- b. Adjust slug in T₁ for 300 Kc output as read on the 524D Electronic Counter.
- c. Rotate FREQ TUNING dial to 1 Mc.
- d. Adjust C2 for a 1 Mc output.

5-28. FREQUENCY RESPONSE ADJUSTMENT (0.3 Mc to 10 Mc).

5-29. This adjustment should be made after it is verified by procedures, Paragraphs 5-10 through 5-12 that the frequency response is out of specification.

- a. Use the test setup shown in Figure 5-2 and the procedure in Paragraph 5-11, steps a through f.
- b. Change the 739AR RANGE SELECTOR to the 3 Mc to 10 Mc range and adjust AMPLITUDE control until the METER pointer is on SET LEVEL.
- c. Sweep through the frequency range 3 Mc to 10 Mc adjusting C16, on the Diode Assembly Board, for minimum deviation from zero of the nullmeter. (Readjust AMPLITUDE at each frequency so that the METER pointer is on SET LEVEL.) If C16 does not have sufficient range for flattening the curve, increase the capacitive value of C17 maximum.
- d. Check the deviation from zero of the nullmeter from 0.3 to 10 Mc. (The nullmeter pointer on SET LEVEL.) Deviation should not be more than ±82 microvolts from 0.3 to 5 Mc and ±82 microvolts and -200 microvolts from 5 Mc to 10 Mc.

5-30. FREQUENCY RESPONSE MONITORING CIRCUIT (5 cps to 10 Mc).

5-31. There is no additional adjustment for the Frequency Response Monitoring Circuit. If out of specifications after adjustment (Paragraph 5-29) try changing tubes; then repeat adjustment Paragraph 5-29.

5-32. TROUBLESHOOTING PROCEDURES.

5-33. This section contains procedures designed to assist in the isolation of malfunctions. These operations should be undertaken only after it is insured that the difficulty cannot be eliminated by the Adjustment and Calibration Procedures.

5-34. POWER SUPPLY VOLTAGE CHECKS.

- a. Unregulated voltage +325 to +375 volts (pin 7 of V5)
-325 to -375 volts (insulated can of C21)

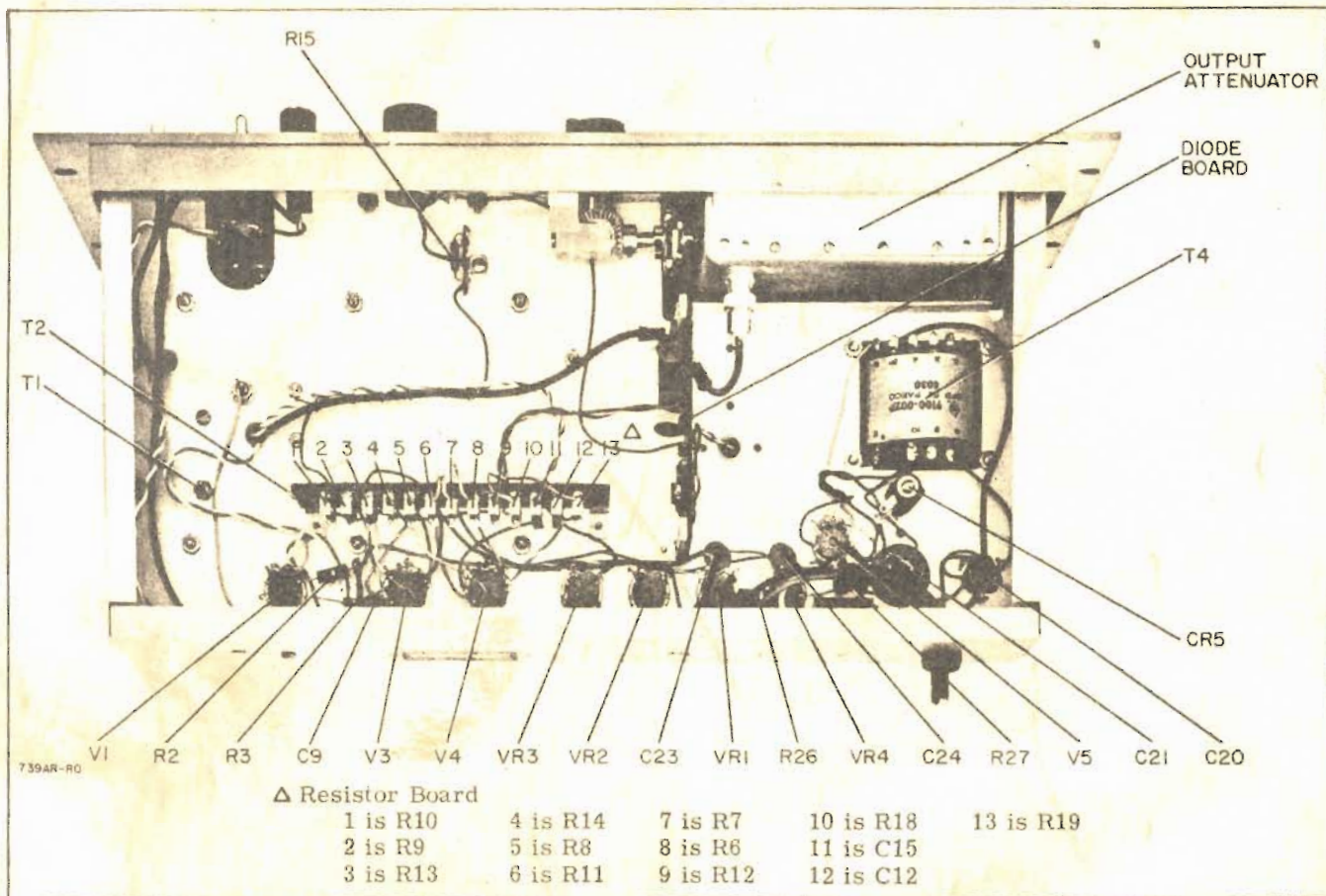

Figure 5-3. Bottom View

- b. Regulated voltage +240 to +260 volts (pin 1 of VR1)
-240 to -260 volts (pin 7 of VR4)
- c. Ripple on regulated supply should be less than 35 millivolts.

5-35. DC AMPLIFIER VOLTAGE CHECKS.

Under the following conditions:

V1 (6C4) out of socket
 RANGE Selector 0.3 to 1 Mc
 AMPLITUDE fully CCW

Approximate
Voltages

Neg. Supply at the junction of R9,
 R10, R13 -250 v
 Pos. Supply at the junction of R6,
 R7, R11 +250 v
 Grids of V4 (pin 2, pin 7) 0 v
 Cathodes of V4 (pin 3, pin 8) +1 v
 Plates of V4 (pin 1, pin 6) +90 v
 Cathodes of V3 (pin 3, pin 8) -54 v
 Output plate of V3 (pin 1) +5 to +250 v
 (Advance amplitude to get +250
 volts.)

5-36. OSCILLATOR AND DC AMPLIFIER ISOLATION OF TROUBLES.

- a. No range operates.
 Check cathode voltage of V1 pin 7 (100 volts).
 - 1. If over 100 volts:
 Check tuning capacitor for short between stator and rotor and for +150 volts.
 - 2. If under 100 volts:
 Check plate, pin 5, of V1 (operating voltage +300 v). If OK, pull V1 tube and check grid voltage, pin 6. If less than 100 v (amplitude cw), the trouble is in the DC Amplifier. (Use voltage checks in Paragraph 5-35.)
- b. One range does not operate.
 Check for open plate coil for that range, tickler coil or trimmer capacitor.

5-37. METER SET CONTROL MALFUNCTION.

- a. Control does not vary meter pointer. (Check R22.)
- b. Control does not vary meter pointer above and below SET LEVEL (2.85 volts applied). Change ohmic size of R23* if R22 will not adjust enough.

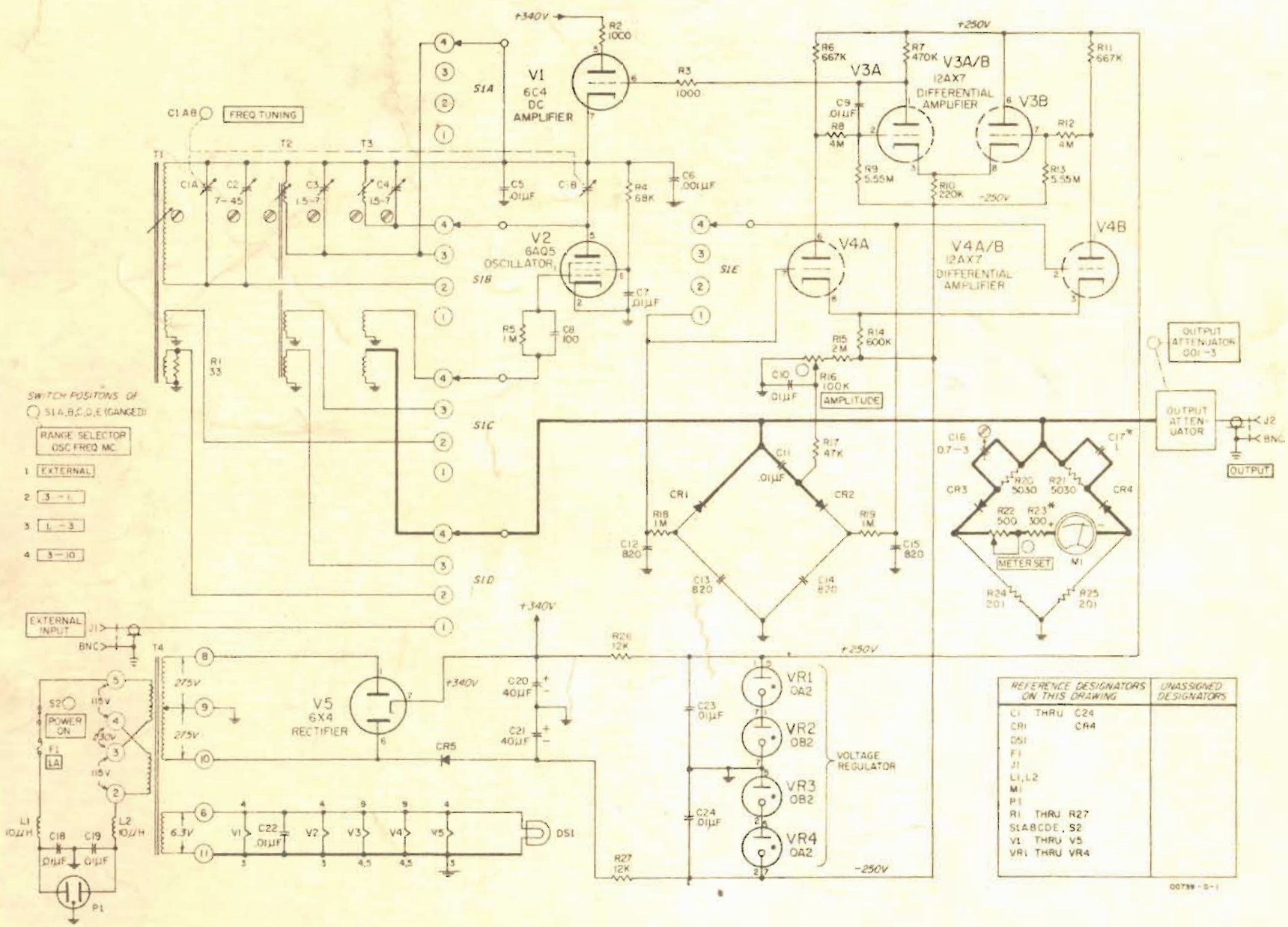



Figure 5-4 Model 739AR Schematic



WARRANTY

All our products are warranted against defects in materials and workmanship for one year from the date of shipment. Our obligation is limited to repairing or replacing products (except tubes) which prove to be defective during the warranty period. We are not liable for consequential damages.

For assistance of any kind, including help with instruments under warranty, contact your authorized  Sales Representative for instructions. Give full details of the difficulty and include the instrument model and serial numbers. Service data or shipping instructions will be promptly sent to you. There will be no charge for repair of instruments under warranty, *except transportation charges*. Estimates of charges for non-warranty or other service work will always be supplied, if requested, before work begins.

CLAIM FOR DAMAGE IN SHIPMENT

Your instrument should be inspected and tested as soon as it is received. The instrument is insured for safe delivery. If the instrument is damaged in any way or fails to operate properly, file a claim with the carrier or, if insured separately, with the insurance company.

SHIPPING

On receipt of shipping instructions, forward the instrument prepaid to the destination indicated. You may use the original shipping carton or any strong container. Wrap the instrument in heavy paper or a plastic bag and surround it with three or four inches of shock-absorbing material to cushion it firmly and prevent movement inside the container.

GENERAL

Your authorized  Sales Representative is ready to assist you in any situation, and you are always welcome to get directly in touch with Hewlett-Packard service departments:

CUSTOMER SERVICE

Hewlett-Packard Company
395 Page Mill Road
Palo Alto, California, U.S.A.
Telephone: Davenport 6-1755
Direct Dial Area Code 415
TWX No. PAL AL 117-U
Cable: "HEWPACK"

OR (In Western Europe)

Hewlett-Packard S.A.
Rue du Vieux Billard No. 1
Geneva, Switzerland
Telephone: (022) 26. 43. 36
Cable: "HEWPACKSA"



MANUAL CHANGES

MODEL 739A

FREQUENCY RESPONSE
TEST SET

Manual Serial Prefixed: 010-
Manual Printed 12/60

To adapt this manual to instruments with other serial prefixes check for errata below, and make changes shown in tables.

Instrument Serial Prefix	Make Manual Changes	Instrument Serial Prefix	Make Manual Changes
944-	1		

CHANGE 1

R4: Change to 82K;  Stock No. 0687-8230.

hp MANUAL CHANGES

MODEL 739A

FREQUENCY RESPONSE TEST SET

Manual Serial Prefixed: 010-
Manual Printed: 12/60

To adapt this manual to instruments with other serial prefixes check for errata below, and make changes shown in tables.

Instrument Serial Prefix	Make Manual Changes	Instrument Serial Prefix	Make Manual Changes
010-	ERRATA		
220-	1, ERRATA		

ERRATA:

Table of Replaceable Parts,

CR3, 4: Change Ⓢ Stock No. to 1901-0027.

SRI: Change description to read: "Rectifier,
selenium, 192V rms max, 25 ma dc max."

Table of Replaceable Parts, under MISCELLANEOUS,
Fuseholder: Change Ⓢ Stock No. to 1400-0084.

CHANGE 1

Table of Replaceable Parts, under MISCELLANEOUS,
Attenuator Assembly: Change Ⓢ Stock No. to
739A-34A.

